



SUBMERSIBLE SEAWATER-RESISTANT SEWAGE PUMPS



Submersible Seawater-Resistant Sewage Pumps

Handling seawater with submersible pumps for a long term period is not an easy task. When pumps are not equipped with adequate specifications for use in seawater, corrosion in metal sections may cause the pumps to become worse in terms of performance, or in the worst case scenario, suffer a breakdown.

Supported by demonstrative experiments using seawater over a long time, Tsurumi has continued unremitting research into submersible seawater-resistant pumps, combining both corrosion resistance and durability. As a result, by giving the maximum possible consideration to economy, reliability and dependability, Tsurumi has successfully developed its original submersible seawater-resistant sewage pumps, which have achieved the upgrading of pumps to a level that allows them to withstand even the seawater.

Tsurumi offers a product lineup comprising two series: B-series pumps equipped with channel impeller and C-series pumps equipped with cutter impeller, with the motor output varying from 0.75 up to 15 kW depending on the model. As part of the seawater-resistant specifications, these pumps are provided with a **Duplex stainless steel shaft, a frame and a casing made of FC250 cast iron, 3-layered Epoxy resin paint coating, and a Galvanic anode (optional)**, with a choice of either 316 stainless steel (DS version) or FC250 (DF version) as the impeller material. In addition, these pumps are equipped with an anti-wicking cable, motor protector, dual inside mechanical seals with silicon carbide faces, Oil Lifter and the like, as in the case with standard Tsurumi products.

Submersible seawater-resistant sewage pumps have a wide range of uses including sewage drainage mixed with seawater, transfer of sewage/wastewater from water treatment facilities in plants and commercial buildings, water intake/discharge at pumping stations and shipyards in coastal areas, desalination plants and the like.

Provided with outstanding reliability, excellent durability and stable quality, Tsurumi's pumps are designed to ensure continuous duty under harsh service conditions over a long period, thereby contributing to stable operation of facilities and allowing substantially reduced maintenance costs at water treatment facilities.

Selection Table

		DS version [Example Model 100B43.7-DS]	DF version [Example Model 100B43.7-DF]
Applicable Series		B-series (Channel Impeller) C-series (Cutter Impeller)	
Discharge Bore	mm	50 - 150	
Motor Output	kW	0.75 - 15	
Materials	Shaft	Duplex Stainless Steel (JIS Grade SUS329J4L)	
	Cast Iron Grade	FC250	
	Suction Cover	FC250 Cast Iron (B-series) High-chromium Cast Iron (C-series)	
	Impeller	316 Stainless Steel Casting	FC250 Cast Iron
Surface Painting		Epoxy Resin Paint	
Galvanic Anode		Option	

B-series

Channel Impeller

The B-series is a submersible channel impeller pump designed for handling raw sewage, wastewater and heavy-duty industrial applications, where the pump is subject to complete submersion and requires maximum reliability.



C-series

Cutter Impeller

The C-series is a submersible cutter pump for sewage and wastewater, which is made of casting and equipped with cutting mechanism. Featuring a combination of impeller vane with brazed sintered tungsten carbide alloy edge and a suction cover of serrated shape, the C-series pumps enable smooth pumping, while cutting solid and fibrous matter during suction.



Mechanism of Metal Corrosion

If seawater-resistant measures are not taken in seawater applications, metal parts corrode, which causes performance drop that can result in pump failure. One suspected cause of corrosion in metallic parts by seawater is the “metal corrosion potential.”

In seawater, a metal’s resistance to corrosion can be seen clearly. As shown in the illustration of <Bimetallic Corrosion in Seawater>, when metals of different potential contact one another, only the metal of lower potential will corrode while the metal of higher potential is protected from corrosion.

The table of <Potentials of Various Metals in Seawater> shows the corrosion strength/weakness of various metals.

When the metal of higher electrode potential, **duplex stainless steel, SUS329J4L** is in contact with a metal of lower electrode potential, 316 stainless steel or cast iron, duplex stainless steel is protected from corrosion. Weaker metal, common stainless steel or cast iron, corrodes away.

Therefore, when shaft material is SUS329J4L and the impeller is made of 316 stainless steel or cast iron, shaft is eventually protected from corrosion and the impeller acts as a galvanic anode. The impeller needs to be replaced every few years depending on operating conditions. However, replacement of the impeller costs far less and is easier than that of the shaft. Hence the material combination brings notable benefits to reduce repairing cost and enhance maintainability for pump usage in a long time.

<Bimetallic Corrosion in Seawater>

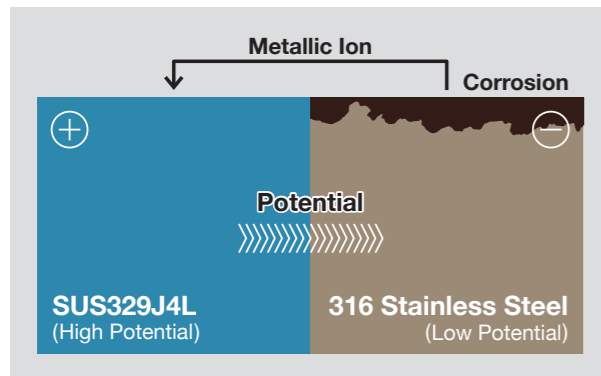

<Potentials of Various Metals in Seawater>

Metal	Potential
Titanium	High (Corrosion-Resistant)
SUS329J4L (Duplex Stainless Steel)	
316 Stainless Steel	Low (Corrosive)
304 Stainless Steel	
420 Stainless Steel	Low (Corrosive)
Cast Iron	
Aluminium Alloy	
Aluminium	
Zinc	
Magnesium	

Duplex Stainless Steel – JIS Grade SUS329J4L (EN 1.4481) – Shaft Material

Duplex stainless steel SUS329J4L is a 25% chromium duplex ferritic-austenitic stainless steel designed to provide a superior combination of high strength and excellent corrosion resistance for a wide variety of applications, especially in corrosive seawater usage.

This alloy consists a microstructure of a balanced mixture of austenite and ferrite. The combination of these phases develops the unique combination of strength and resistance for chloride stress-corrosion cracking of this alloy.



FC250

Cast Iron Material

Cast iron components are made of FC250 grade gray cast iron. FC250 cast iron has higher resistance under tension and is also harder than FC200 cast iron material.



Epoxy Resin Paint

Surface Painting

3 layers of epoxy resin provide extra protection to the metallic components of the pump from direct exposure to corrosive medium. 180µm of minimum thickness has been maintained throughout the painted components. Epoxy layer preventing direct exposure of metallic components to corrosive medium acts as an electrical resistance between metal and the medium, and hence improves corrosion resistance.



Galvanic Anode (option)

Cathodic Protection

The galvanic anode is an electrolytic protective measure used with metals of differing corrosive potentials. Metals of a potential lower (aluminium and zinc) than the pump body (cast iron and steel) are brought into contact with the body via the galvanic anodes and allowed to corrode in order to protect the body. However, the full effect cannot be obtained unless the anodes are installed in the proper positions.

Tsurumi mainly utilizes aluminium because of its superior anticorrosive performance per unit weight, while utilizing zinc for only the strainer stand that is liable to be worn by water current. Since the galvanic anodes are worn by corrosion, they need to be replaced every two years. They can be replaced easily and used immediately after replacement.



Aluminium



Zinc

Corrosion Test (in seawater / 1 year)



without galvanic anode



with galvanic anode installed

Performance Curves

• For 60 Hz models, please contact your dealer.

B-series Channel Impeller

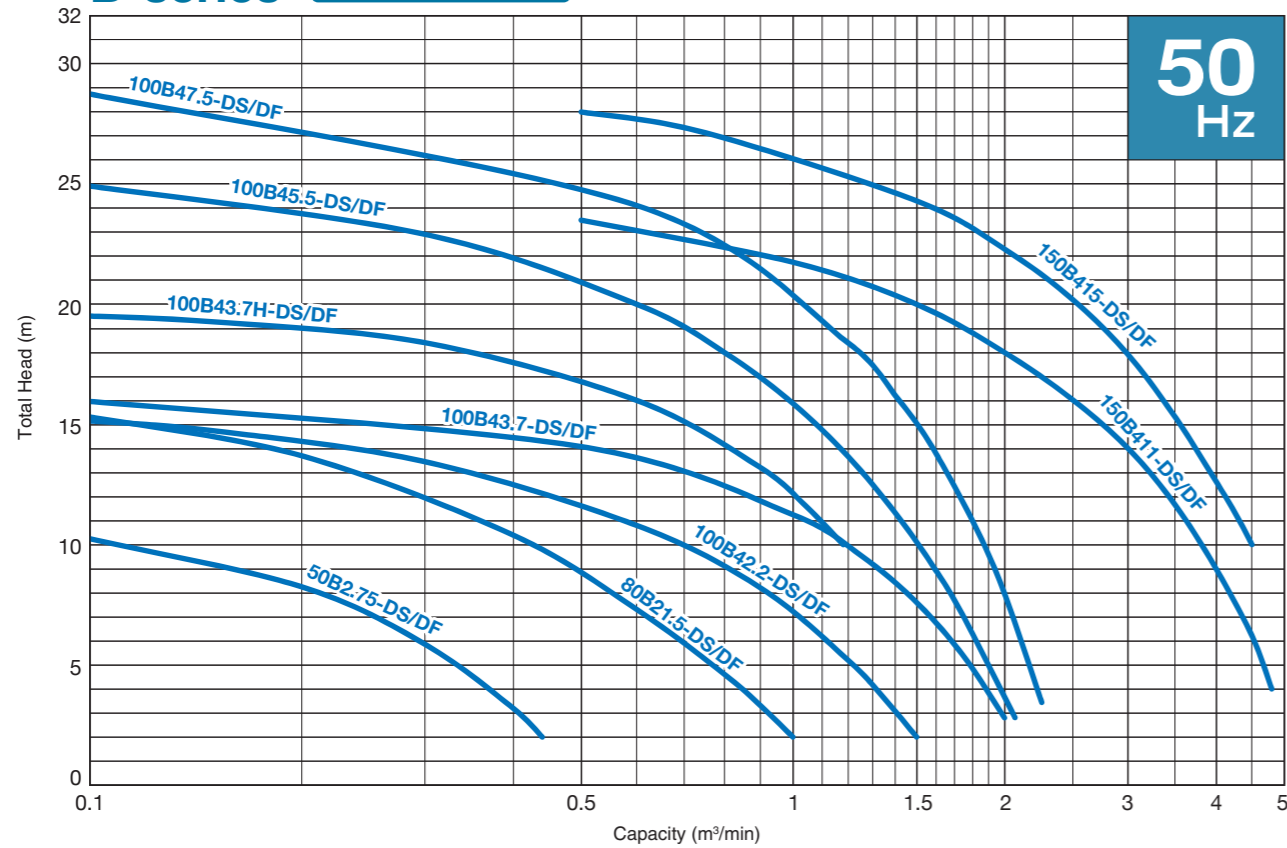

C-series Cutter Impeller

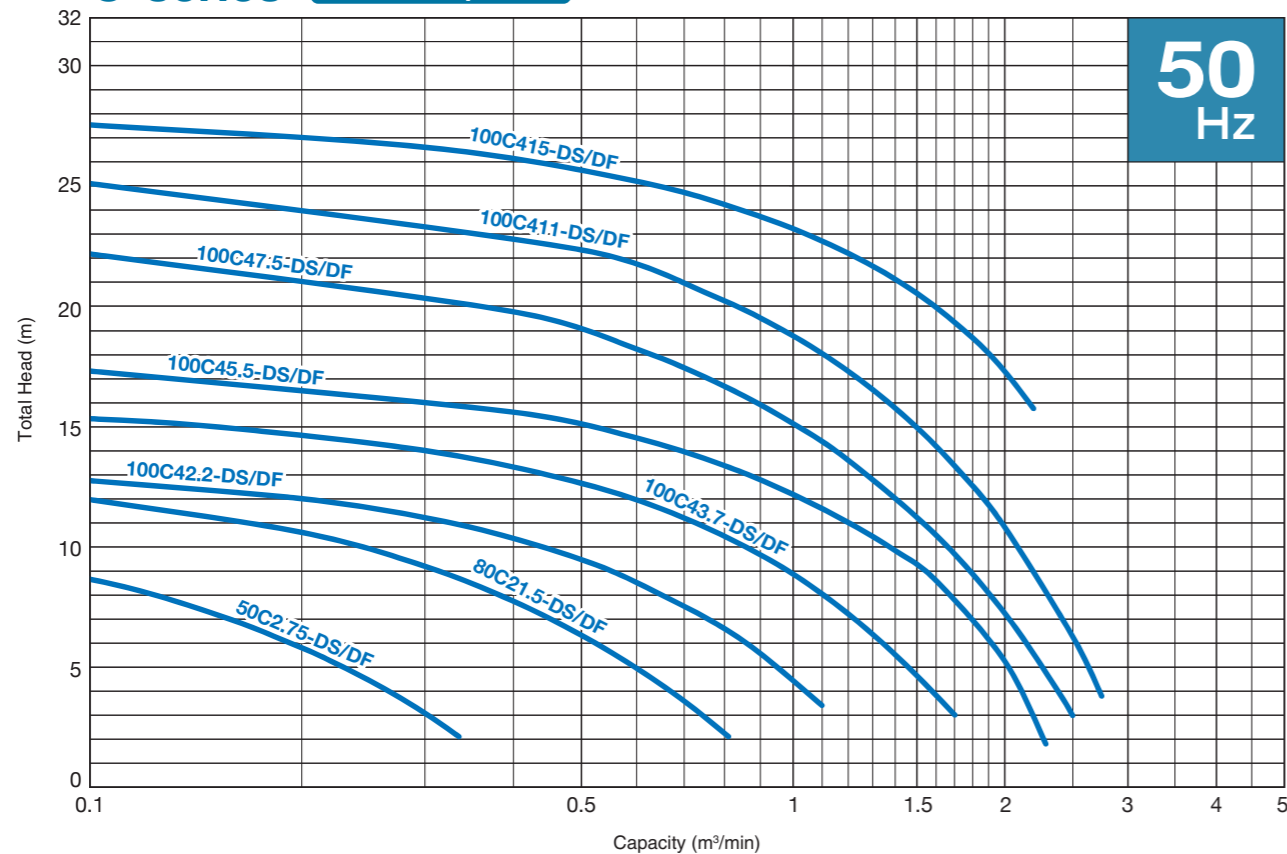

Model Selection

	Model		Discharge Bore mm	Motor Output kW	Phase	Pole	Starting Method	Dimensions L x W x H mm	Dry Weight kg	Cable Length m
	DS version (316 Stainless Steel)	DF version (FC250 Cast Iron)								
B -Channel Impeller-	50B2.75-DS	50B2.75-DF	50	0.75	Three	2	D.O.L.	405 x 250 x 439	25	6
	80B21.5-DS	80B21.5-DF	80	1.5		2	D.O.L.	446 x 250 x 536	36	6
	100B42.2-DS	100B42.2-DF	100	2.2		4	D.O.L.	596 x 324 x 616	68	6
	100B43.7-DS	100B43.7-DF	100	3.7		4	D.O.L.	601 x 333 x 690	84	6
	100B43.7H-DS	100B43.7H-DF	100	3.7		4	D.O.L.	603 x 344 x 666	82	6
	100B45.5-DS	100B45.5-DF	100	5.5		4	D.O.L.*1	686 x 410 x 908	140	8
	100B47.5-DS	100B47.5-DF	100	7.5		4	D.O.L.*1	686 x 410 x 929	154	8
	150B411-DS	150B411-DF	150	11		4	Star-Delta	895 x 490 x 1097	245	8
	150B415-DS	150B415-DF	150	15		4	Star-Delta	895 x 490 x 1167	266	8
	C -Cutter Impeller-	50C2.75-DS	50C2.75-DF	50		0.75	2	D.O.L.	405 x 250 x 415	24
80C21.5-DS		80C21.5-DF	80	1.5	2	D.O.L.	446 x 250 x 536	36	6	
100C42.2-DS		100C42.2-DF	100	2.2	4	D.O.L.	596 x 324 x 616	68	6	
100C43.7-DS		100C43.7-DF	100	3.7	4	D.O.L.	601 x 333 x 690	84	6	
100C45.5-DS		100C45.5-DF	100	5.5	4	D.O.L.*1	686 x 410 x 908	133	8	
100C47.5-DS		100C47.5-DF	100	7.5	4	D.O.L.*1	686 x 410 x 929	144	8	
100C411-DS		100C411-DF	100	11	4	Star-Delta	709 x 436 x 1000	179	8	
100C415-DS		100C415-DF	100	15	4	Star-Delta	707 x 436 x 1080	221	8	

*1 Star-Delta available upon request

• Duckfoot bend sets for guide rail fitting system in FC250 + epoxy resin paint are available

• Weights excluding cable

Dimensions

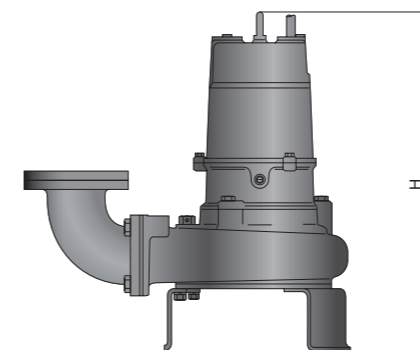
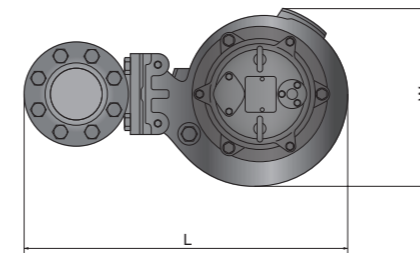

Seawater Pumps

TM-series

Tsurumi also offers submersible seawater pumps, the TM-series.

All the wetted parts of this pump are made of titanium and resin, which provides the highest corrosion resistance to seawater. The TM-series is available in 0.25 to 3.7kW motor output, and both single-phase and three-phase models. For details, refer to the VANCS-series catalog [IA114].





We reserve the right to change the specifications and designs without prior notice. The OO series and model OO are indicated with our series/model codes in this catalog.

**TSURUMI
MANUFACTURING CO., LTD.**

Your Dealer